



Universitat d'Alicant
Universidad de Alicante



- University of Alicante -

Specialized Processor Architectures Lab



**- CIE 2006 Contribution -
'The Role of Algebraic Models
and Type-2 Theory of
Effectivity in Special
Purpose Processor Design'**

Gregorio de Miguel Casado

Juan Manuel García Chamizo



'The Role of Algebraic Models and TTE in Special Purpose Processor Design'

introduction

method

processor
design

conclusions

Contents

- ✚ introduction
 - research motivations
 - background
- ✚ method proposal for processor design
 - Type-2 Theory of Effectivity
 - Algebraic Models of Processors
- ✚ processor design for computable integral transforms
 - problem formalization
 - computability analysis
 - functional specification
 - algebraic specification
- ✚ conclusions

'The Role of Algebraic Models and TTE in Special Purpose Processor Design'

introduction

motivation

background

method

processor
design

conclusions

Research Motivation

"special purpose processor for integral transforms"

Specialized Processor Architectures Lab

→ Scientific Computing

Architecture overview

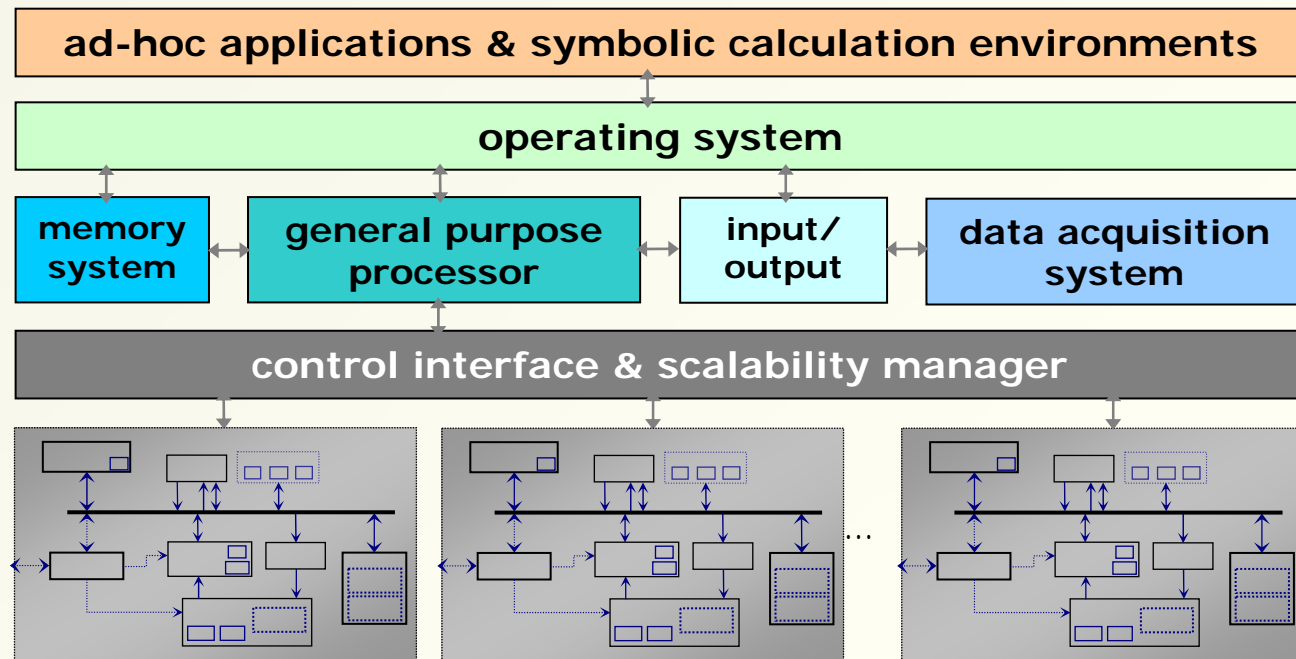

CIE 2006



'The Role of Algebraic Models and TTE in Special Purpose Processor Design'

introduction

motivation

background

method

processor
design

conclusions

CIE 2006

Background

"feasibility barriers in paradigm application"

- ✚ Scientific Computing
 - reliability demands in computer characterization of complex physical problems
 - ➔ **Computable Analysis**
- ✚ VLSI design
 - correctness in specification and verification of processors
 - ➔ **Formal Methods: Algebraic Models**
- ✚ Computer Arithmetic
 - limited hardware support for arithmetic precision management (IEEE 754)
 - ➔ **signed-digit arithmetic**
- ✚ Technology trends
 - ➔ **hybrid chips (μP + ad-hoc hardware)**
 - ➔ **memory integration improvements**

'The Role of Algebraic Models and TTE in Special Purpose Processor Design'

introduction

method

Type-2 Theory
of Effectivity

Algebraic
Models
sketch

processor
design

conclusions

CIE 2006

Type-2 Theory of Effectivity

- ✚ Provides a coherent bridge between two classical disciplines: analysis/numerical analysis and computability/complexity theory
 - ✚ Presents a realistic model of computation based on Type-2 machines
 - ✚ Provides a concrete computability concept based on naming systems and realizations
 - ✚ Allows the definition of computable functions on the set of all real numbers
 - ✚ Allows a natural complexity theory
- **The representations based on signed-digit notation are feasible for developing ad-hoc hardware arithmetic support (precision criteria)**
- **The amount of memory available limits the feasibility of representation implementation**

'The Role of Algebraic Models and TTE in Special Purpose Processor Design'

introduction

method

Type-2 Theory
of Effectivity

Algebraic
Models

sketch

processor
design

conclusions

CIE 2006

Algebraic Models of Processors

- ✚ Formal paradigm for VLSI design
 - ✚ Allows the isolation some fundamental scientific structural features of processor computation (behavior over time and of data representation and operation)
 - ✚ Specification and verification of computer architecture techniques (microprogramming), and models (pipelined and superscalar processors)
 - ✚ Connection with verification tools such as Maude and HOL
- **Algebraic abstraction support for complex computer architectures**
- **Realistic approach by levels: Programmer & Abstract Circuit**

'The Role of Algebraic Models and TTE in Special Purpose Processor Design'

introduction

method

processor
design

problem
formalization

computability
analysis

specification

conclusions

CIE 2006

Formalization of Requirements

✚ **INPUT:** informal problem description

✚ **OUTPUTS:**

- Mathematical expression. Convolution between Lebesgue integrable functions in $L_1(\mathbb{R})$

$$h(x) = f * g(x) = \int_{\mathbb{R}^d} f(x-y)g(y)dy = \int_{\mathbb{R}^d} f(y)g(x-y)dy$$

- Processor requirements and restrictions

- Support for heterogeneous data sources (symbolic calculation programs and real world data series)
- Support for scalability features by levels of parallelization of the calculation
- Support for variable precision capabilities in order to cover a wide range of precision requirements
- Support for calculation time restrictions and result quality management

- Test scenarios



'The Role of Algebraic Models and TTE in Special Purpose Processor Design'

introduction

method

processor
design

problem
formalization

computability
analysis

specification

conclusions

Computability Analysis

✚ INPUTS:

- Mathematical expression
- Precision requirements

✚ OUTPUTS:

- Computable representation of convolution operation between Lebesgue integrable functions in $L_1(\mathbb{R})$ spaces
 - rational step functions
 - normalized signed digit notation
- Complexity Analysis



'The Role of Algebraic Models and TTE in Special Purpose Processor Design'

introduction

method

processor
design

problem
formalization

computability
analysis

specification

conclusions

Specification

✚ INPUTS:

- Requirements and restrictions
- Computable representations and algorithms

✚ **OUTPUT:** Algebraic Specification of the processor

'The Role of Algebraic Models and TTE in Special Purpose Processor Design'

- introduction
- method
- processor design
- problem formalization
- computability analysis
- specification
- conclusions

CIE 2006

Functional Specification

✚ Modules

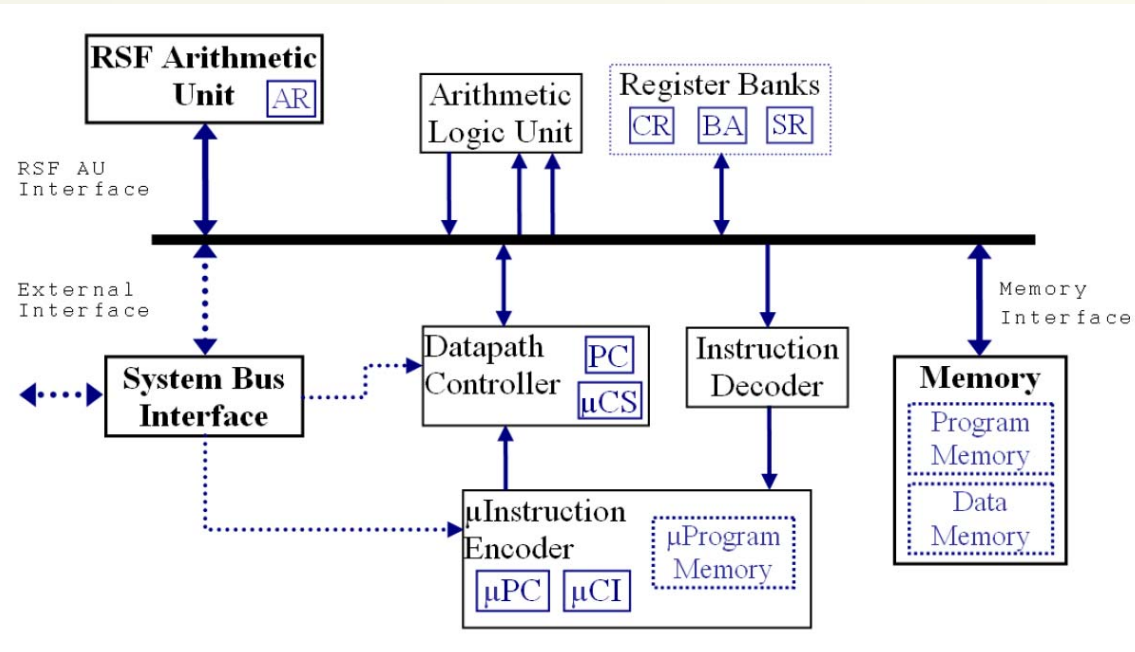

- ✚ Instruction set (Status_Request, Configuration_Request, Configuration_Set, Halt, Convolution)
- ✚ Banks of registers (Configuration, Base-Adress, Status, Arithmetic)



'The Role of Algebraic Models and TTE in Special Purpose Processor Design'

introduction

method

processor
design

problem
formalization

computability
analysis

specification

conclusions

CIE 2006

Algebraic Specification

✚ Programmer's level

- state and next state algebras
- machine algebra
- next state and output function

✚ Abstract circuit level

- program memory
- data memory organization
- rational step function arithmetic unit
- control unit
- state and next state algebras
- machine algebra
- next state and output function

'The Role of Algebraic Models and TTE in Special Purpose Processor Design'

- introduction
- method
- processor design
- problem formalization
- computability analysis
- specification
- conclusions

CIE 2006

Algebraic Specification. Data memory organization

- ✚ Mapping functions: $\rho_{head_name}, \rho_{addrF}, \rho_{addrRSF}, \rho_{headStep}, \rho_{addrRangeStep}, \rho_{addrLint}, \rho_{addrHint}, \rho_{addrA}, \rho_{addrB}, \rho_{addrCr}, \rho_{addrCi}, \rho_{RangeStep}, \rho_{IInterval}, \rho_{HInterval}, \rho_a, \rho_b, \rho_{Cr}, \rho_{Ci}$
- ✚ Data memory mapping

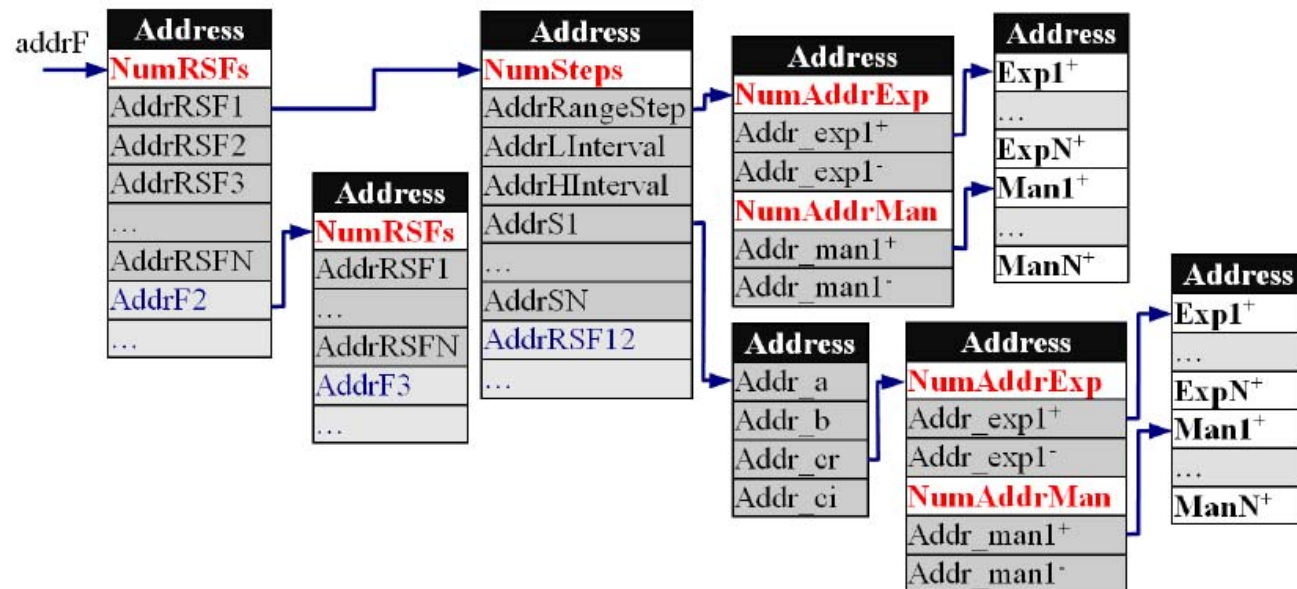

'The Role of Algebraic Models and TTE in Special Purpose Processor Design'

- introduction
- method
- processor design
- problem formalization
- computability analysis
- specification
- conclusions

CIE 2006

Algebraic Specification. Data memory storage

✚ Normalized signed-digit representation

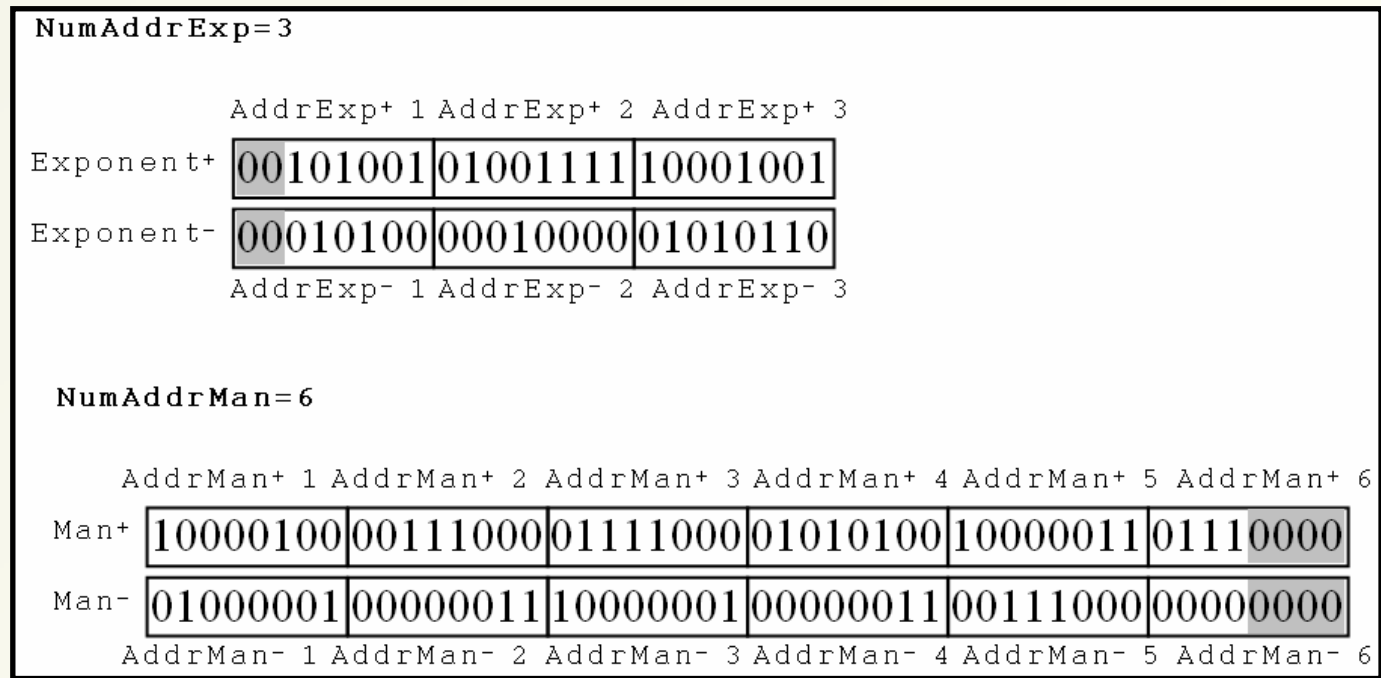



'The Role of Algebraic Models and TTE in Special Purpose Processor Design'

introduction

method

processor
design

conclusions

Conclusions

- ✚ Novel theoretical approach for designing a processor for computable scientific computing calculations
 - Type-2 Theory of Effectivity
 - Algebraic Models of Processors
- ✚ Case of study: Convolution between functions $L_1(\mathbb{R})$
- ✚ Research in progress
 - Complete algebraic specification and verification
 - Prototype implementation and performance evaluation



Universitat d'Alicant
Universidad de Alicante



- University of Alicante -

Specialized Processor Architectures Lab



**- CIE 2006 Contribution -
'The Role of Algebraic Models
and Type-2 Theory of
Effectivity in Special
Purpose Processor Design'**

Gregorio de Miguel Casado

Juan Manuel García Chamizo